

Thank you for choosing the COYOTE Pen Kit!

PREMIUM PEN KIT

CLICK
PEN!

Coyote

Other Kits
Available!



Visit McKenziePenworks.com for additional information and premium blanks!

US MADE STAINLESS

COYOTE PEN KIT - ASSEMBLY INSTRUCTIONS

1: Cut a blank to approximate length (at least 64mm or 2 5/8") then drill with 3/8" drill bit before gluing in brass tube. We recommend using epoxy for best results.

2: Carefully sand or trim blank flush with brass tube. Excessive trimming could result in the refill sticking out too far.

3: Using a mandrel or centers, turn the blank on your lathe to the diameter of the bushings.

4: After finishing the turned blank, carefully press the front section into the smaller diameter (.440") end of the blank.

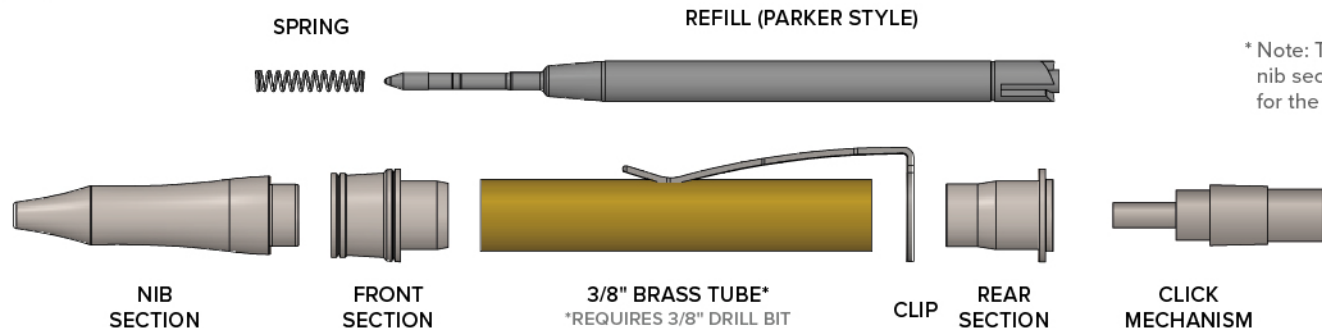

* Note: The smaller bushing (1 line) is for the nib section, the larger bushing (2 lines) is for the finial.

5: Place the rear section piece through the hole in the clip and press into the larger diameter side of the blank (.476")

6: Screw the Schmidt Click Mechanism into the rear section.

7: Put the refill into the pen from the front section, place the spring on the end of the refill, and screw the nib section onto the pen.

