

MINI SKETCH PENCIL — Kit and Assembly Instructions

KIT FEATURES

- Available in 24kt Gold and Chrome Plating
- Click operating mechanism
- Uses 3mm leads — **PKSPCL3X**.
- Pencil plunger has built-in sharpener
- Overall Length: 4-1/2"

REQUIRED ACCESSORIES

- 7mm, Pen Mandrel
- 2-piece Bushing Set **#PKSPCL3BU**
- 8mm Drill Bit **#PKPARK-8MM**
- Universal Barrel Trimmer **#PKTRIMKIT** (use 8mm)
- 2 Part Epoxy Glue or Insta-Cure (cyanoacrylate) Glue

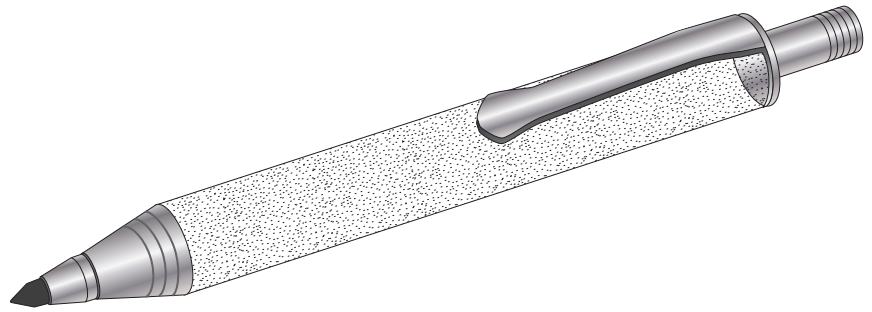
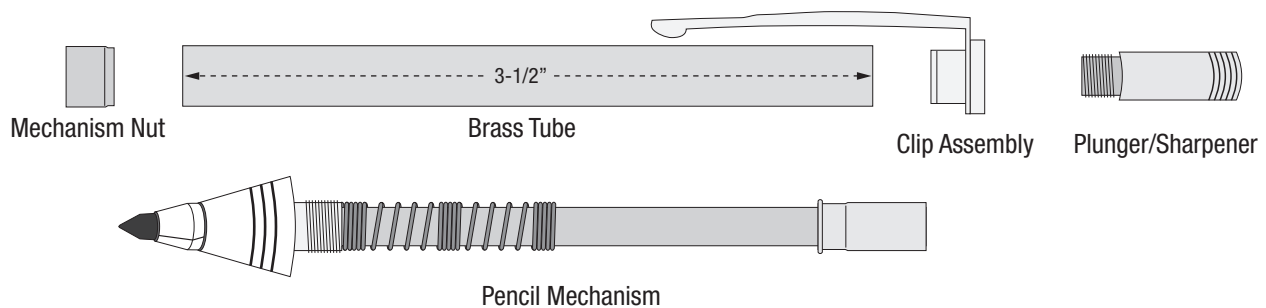

DIAGRAM A • Pen Parts



PREPARING THE BLANKS

- From 5/8" square stock, the wood or acrylic blank to the length of the brass tubes. Add 1/16" for squaring off.
- Drill an 8mm centered hole lengthwise through the blank.
- Glue the brass tube in the blank. Spread the glue on the tube. Insert into the blank with a twisting motion to spread the glue evenly inside. Center the tube lengthwise in the blank. Allow it to dry.
- After the glue dries, use a 8mm Barrel Trimmer to square the ends of the blank flush with the ends of the brass tube.

TURNING THE BLANKS

- Place spacer bushings onto the pen mandrel. Slide an end bushing onto the mandrel, wide end in first. Insert the blank and follow with the second bushing (narrow end first). Add additional spacer bushings to close the space to the threads on the mandrel. Thread the locknut onto the mandrel handtight. Bring the tailstock in snug with the mandrel. Do not overtighten—this could damage the pen mandrel. Lock the nut and the tailstock in place.
- Turn the blanks down close to the bushings located at the ends of the blanks. Sand the blanks down to the bushings.
- Finish the turned barrels with your choice of PSI polish.

DIAGRAM B • Turning The Blanks

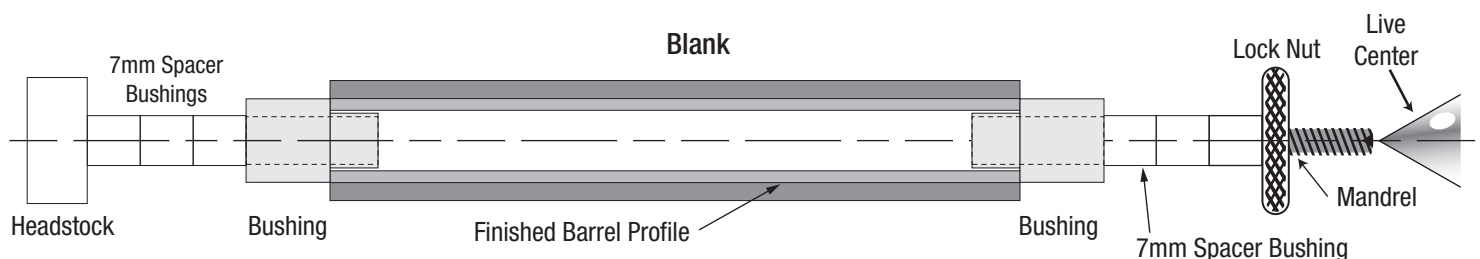
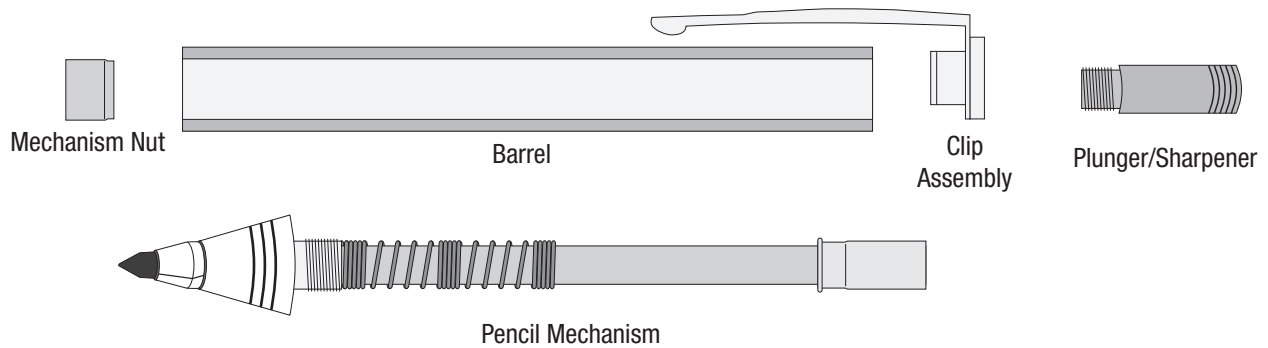

DIAGRAM C • Assembly



PEN ASSEMBLY

- Line up parts according to **DIAGRAM C** above.
- Press the Mechanism Nut into either end of the barrel.
- Press the clip assembly into the opposite end of the barrel.
- Slide the barrel—mechanism nut end first—over the Mechanism Assembly and screw on the tip end.
- Screw on the Plunger/Sharpener through the cap end
- To sharpen lead point, unscrew plunger with built-in sharpener and rotate over the exposed lead.
- To replace or refill with lead, press the plunger and hold down. The jaws holding the lead will release the lead. Slide a new lead stick through the open jaws to the desired extension.

BUSHINGS

DIAGRAM D • PKSPCL3BU



Diameter A: .435"
 Diameter B: .285"
 Inner hole diameter: .248"

