

The Raptor Setup Tool *Patent Pending*

Raptor Setup Tools simplify the sharpening process so you can spend more time turning and less time sharpening. They make set up and sharpening a breeze while delivering consistent, repeatable results every time.

How does it work?

Because the Raptor Setup tool establishes the exact same distance from the wheel face and tool support each time you sharpen, you achieve an identical bevel angle every time. This reduces time spent sharpening and increases the life of your tools. Raptor Setup tools makes sharpening easy and repeatable... the way it should be! Made in the USA.

Before getting started



Note: Grinder cover removed for illustrative purposes only. Do not operate grinder with cover removed.

1. Make sure that your sharpening system is properly installed with a distance of 6-1/2" between the center of the grinder arbor and the bottom of the clamping base. If this distance is not exact, the actual bevel angle on the tool will not be the same as that indicated on the Raptor Set Up Tool.



2. Set the leg angle on the tool holder to 23 degrees and lock in place. This can be done by using a protractor or by using the diagram on page 3. With a tool mounted in the Vari-Grind Jig, align the tool with the top line then adjust the leg so that the center of the leg lines up with the 23 degree line. Tighten securely.

Note: The adjustable leg on the Vari-Grind tool holder should remain in the 23 degree position at all times when using Raptor set up tools.

Using the Raptor Setup Tool



1. With the grinder completely stopped, place the end of the Raptor tool in the tool support arm as shown. Adjust the support arm as needed so that the two contact points on the Raptor tool contact the wheel face. Lock the support arm securely in place. Remove the Raptor tool.

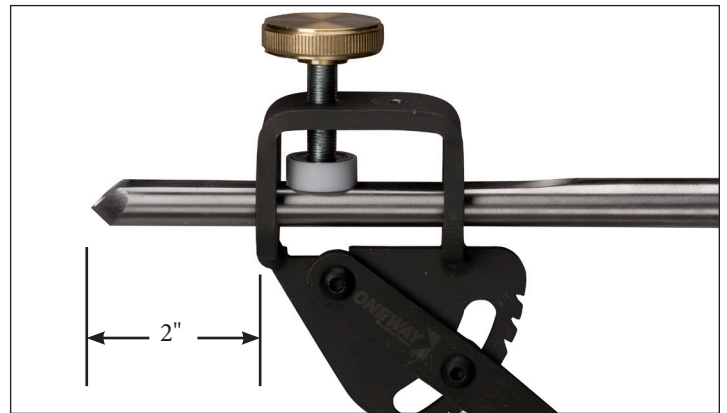

2. Using the 2" Raptor Depth Gauge secure the tool to be sharpened in the tool holder with the tool protruding 2" beyond the tool holder. (1 3/4" if using a 6" grinder). Although the actual bevel angle achieved will vary slightly over time due to wheel wear, it is negligible and will not affect the function or performance of the tool being sharpened.

Grinding a secondary (clearance) bevel on a gouge

A secondary bevel makes it easier to keep the bevel rubbing against the work while cutting. It also prevents scoring marks that occur due to the heel of the bevel rubbing on the work.

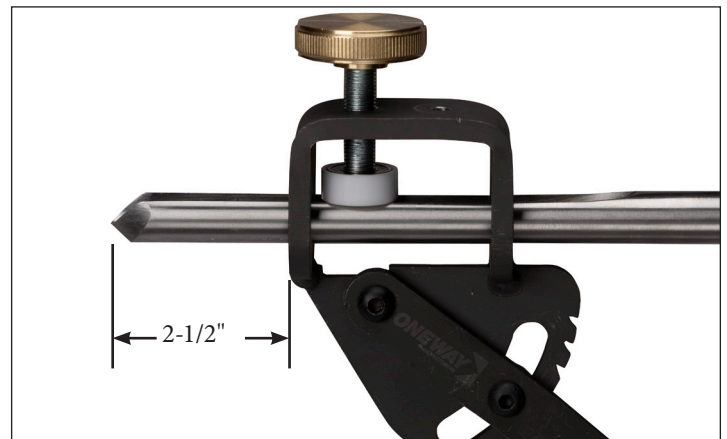

1. Using the 2-1/2" Raptor Jig Guide, secure the tool to be sharpened in the tool holder with the tool protruding 2-1/2" beyond the tool holder. Grind the clearance bevel in a smooth side-to-side motion. Next set the protrusion of your gouge using the 2" Raptor Jig Guide. Sharpen the cutting edge while moving the jig in a smooth side-to-side motion.

 See a video demonstration at www.woodturnerscatalog.com

1-800-551-8876

www.woodturnerscatalog.com

© 2014 Craft Supplies USA. All rights reserved. The Raptor Setup Tool 1

The Recommended Bevel Angles

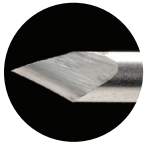

35 degrees: Detail gouges. When a fine point & extra long bevel is desired.

35

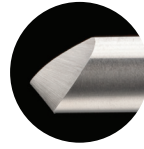

50 degrees: Bowl gouges and roughing gouges

50

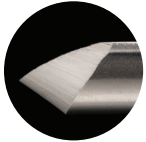

40 degrees: Spindle and detail gouges

40

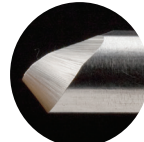

60 degrees: Bowl gouges used for interior cutting. Blunt bevel angle allows the gouge to maintain continuous contact throughout the cut.

60

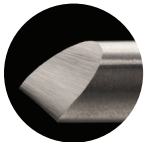

45 degrees: Bowl and general purpose gouges

45

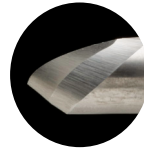

45 degree Double Bevel: Bowl and general purpose gouges with a clearance bevel for optimum bevel contact.

45

**Double
Bevel**

Layout Diagram

