

Turning a Wire Key Ring

Supplies Needed

- Faceplate
- Hardwood Waste Block
- Revolving Center
- Blank
- Double Face Tape
- Sandpaper/Finish
- Eye and Ear Protection
- Masking Tape
- 1 1/2" x 1 1/2" x 6" Square of hardwood
- Drive Center
- Outside Calipers
- Tape Measure

Steps

1. Mount a waste block approximately 2" to 3" in diameter by 1 1/2" thick on a faceplate or in a chuck.
2. Turn a 1 1/2" tenon with a flat face (see figure 1). The tenon will be smaller than the diameter of the finished blank.
3. Cut a wood disc 3/8" to 1/2" thick by 2" in diameter.
4. Check to see that the back of the disc to be turned is sanded flat up to 220 and is dust free.
5. Tape the face of the tenon with double face tape and attach the back of the disc to the double face tape.
6. Place a small piece of scrap wood between the blank and the live center. Advance the live center into the scrapwood (see figure 1). This pressure will strengthen the bond of the tape during the rough turning of the disc.
7. Turn and shape the disc down to 1 23/32" diameter (see figure 1) and remove the live center.
8. With the point of a skew or detail gouge cut a 45 degree vee groove for the wire ring. Test the depth and width of the vee groove by holding the ring in your hand and placing it into the groove. 1/2 of the ring should protrude out of the groove (see figure 2).
9. Now that the groove has been properly sized, shape and finish all exposed surfaces of the disc.
10. When removing the disc, gently wedge a wood chisel between the disc and tenon. Use slow, steady pressure until the tape begins to separate and disc breaks free.

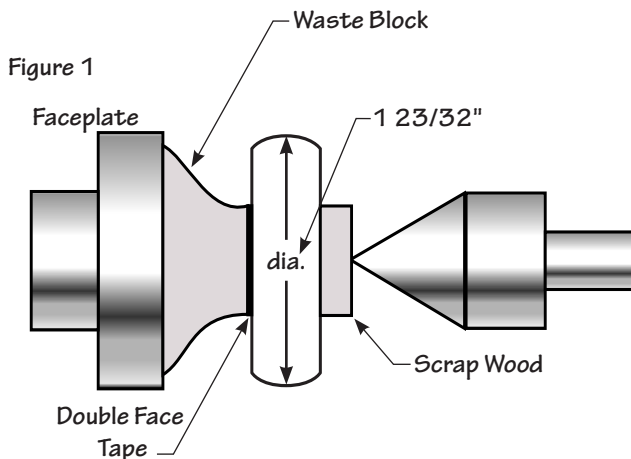

Making a Sanding Mandrel to Notch the Disc

1. Mount a 1 1/2" x 1 1/2" x 6" blank between centers and turn it to a 1 1/4" cylinder (see figure 3).
2. With a pencil make a mark at 1 3/4", at 3 1/2", and at 5 1/4". Turn the lathe on and transfer the mark around the cylinder.
3. Cut sandpaper into strips 1" x 7" long in the following grits: 100, 150, and 220.
4. Cut a 1" long strip of masking tape and apply it to the grit face of the end of the sandpaper strip.
5. Tape the strips to the sanding mandrel using the pencil line to align the sandpaper, clockwise around the mandrel. Place a small loop of tape under the end of the strip in order to keep it rolled around the mandrel.

Making a Notch for Keys with the Sanding Mandrel

1. Select the area of the disc to be notched.
2. While holding the blank firmly in your finger, gently start sanding the edge of the disc with the 100 grit sandpaper. Moving the disc from side-to-side, gently sand the disc until it is about 1" wide (figure 4). Lightly sand through the other grits on the mandrel.
3. Lightly sand any sharp edges of the notched area by hand and apply finish to any unfinished areas.
4. To complete the project, place the ring parallel to the disc face and expand it over the disc into the groove.

Figure 2

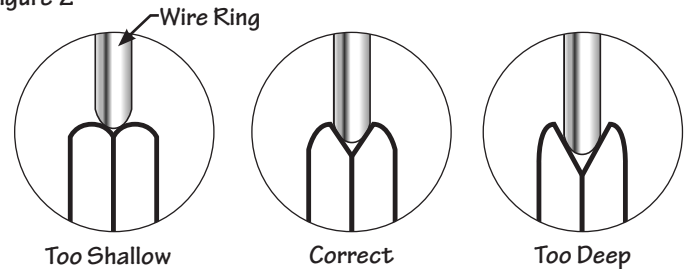

Figure 3

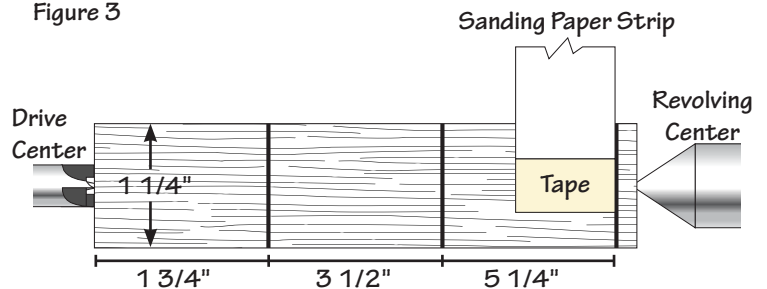

Figure 4

