

## Turning a Light Pull Chain

### Supplies Needed

- 1/8" Drill Bit
- 1/4" Drill Bit
- 3/4" x 3" Blank
- Light Pull Drive
- Revolving Center
- Sandpaper/Finish
- Eye and Ear Protection

### Cutting and Drilling the Blank

1. Select a blank approximately 3/4" diameter x 3" long.
2. Drill a 1/4" diameter hole 3/8" deep in one end of the blank.
3. Drill a 1/8" diameter hole through the center of the blank.

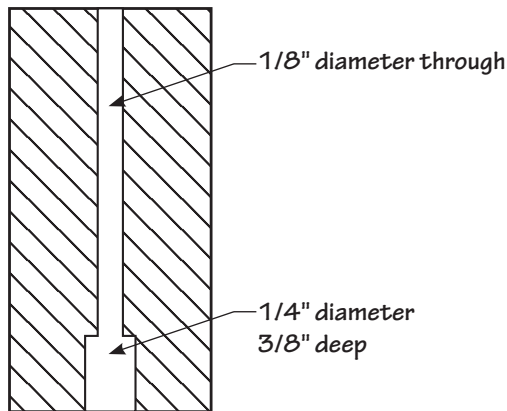

4. Place the blank on the light pull drive or turned wood chuck as shown.
5. Turn to desired shape.
6. Sand and finish.

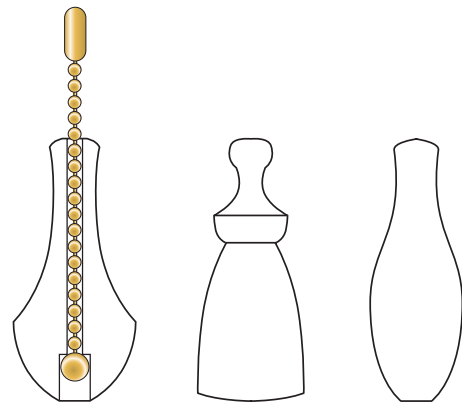
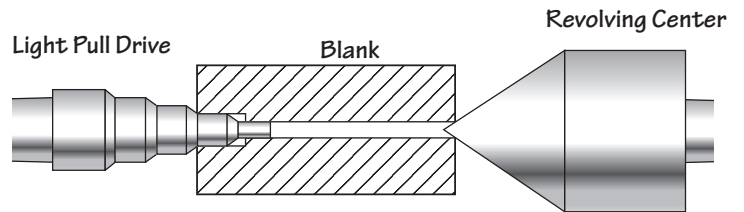

Suggested Shapes